









Unilock Website Structure v1.1

Synapse Cross-Media 05.22.02

Table of Contents

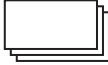
Symbol Codes	ii		
Overview	1		
GATEWAY		GLOBAL LINKS	
0.0 Unilock Website Gateway	2	9.0 Contact Us	29
		9.1 Regional Offices	
MAIN SECTIONS		10.0 About Us	30
1.0 Consumers	3	10.1 Careers	
1.1 Do-It-Yourself		10.2 News	
1.2 Professional Installations		11.0 Site Map	32
2.0 Contractors	8	12.0 Help	34
2.1 Become An Authorized Contractor		12.1 Site Information	
2.2 Training & Resources		12.2 FAQs	
3.0 Design Professionals	10	12.3 Technical Assistance	
3.1 Resources		12.4 Literature & Videos	
4.0 Engineers	11	12.5 E-mail Updates	
4.1 Resources		13.0 Legals	36
5.0 Dealers	12	MAIN FEATURES	
5.1 Dealer Login		14.0 Site Search	37
5.2 Dealer Support		15.0 Dealer Locator	37
5.3 Change Password		16.0 Cost Estimator	37
GLOBAL SECTIONS		OTHER FEATURES	
6.0 Design Ideas	15	17.0 Request a Free Estimate	38
6.1 Design Fundamentals		18.0 Send to a Friend	38
6.2 Residential		19.0 Risi Search	38
6.3 Commercial		20.0 Survey	39
6.4 Industrial		APPENDIX A: Menu Navigation	40
6.5 Environmental		APPENDIX B: Notes of Visual Design	45
6.x.1 Design Ideas Gallery			
6.x.1.1 Installation Detail			
6.6 Installation of the Month			
7.0 Products	21		
7.1 Textured Pavers			
7.2 Standard Pavers			
7.3 Industrial Pavers			
7.4 Environmental Pavers			
7.5 Garden Walls			
7.6 Retaining Walls			
7.7 Accessories			
7.x.1 Product Detail			
7.8 Product Specifications			
7.9 Color Planner			
8.0 Events & Seminars	26		
8.1 Event Listing			
8.1.1 Event Detail			
8.1.2 Registration Form			

Symbol Codes

	Gateway to the site
	Relationships between pages and/or components
	Page components (content or application that appears on a page)
	Page
	Group of similar pages
	Group of files
	Group of related pages or sections
	Continuation Points

Overview

SECTION/PAGE TYPES

1. *Unilock Website Gateway* page (0.0) – the default page for Unilock.com.
It sorts visitors according to the type of user they are (i.e., Consumer, Contractor, Design Professional, Engineer, or Dealer) so that specific marketing messages, information, and promotions can be presented to them.
2. *Global Sections* (9.0–13.0) – these sections are available on virtually all pages of the website.
 - 9.0 Contact Us
 - 10.0 About Us
 - 11.0 Site Map
 - 12.0 Help
 - 13.0 Legals
3. *Main Sections* (1.0–5.0) – these sections correspond to the user-types above.
 - 1.0 Consumers
 - 2.0 Contractors
 - 3.0 Design Professionals
 - 4.0 Engineers
 - 5.0 Dealers
4. *Main Sub-sections* (6.0–8.0) – these sub-sections appear in all of the main sections.
 - 6.0 Design Ideas
 - 7.0 Products
 - 8.0 Events & Seminars
5. *Main Features* (14.0, 15.0, 16.0) – these features are available on all pages of the *Global & Main Sections*.
 - 14.0 Search
 - 15.0 Dealer Locator
 - 16.0 Cost Estimator
6. *Other Features* (17.0–20.0) – these features appear on select pages within the website.
 - 17.0 Request a Free Estimate
 - 18.0 Send to a Friend
 - 19.0 Risi Search
 - 20.0 Survey

0.0 Unilock Website Gateway

This is the first page a visitor typically sees upon entering Unilock.com. It serves two functions:

1. It immediately conveys to the visitor that Unilock is a premiere manufacturer of high quality paver and retaining wall products.
2. It streams visitors into user-specific groups so that specific marketing messages, information, and promotions can be presented to them.

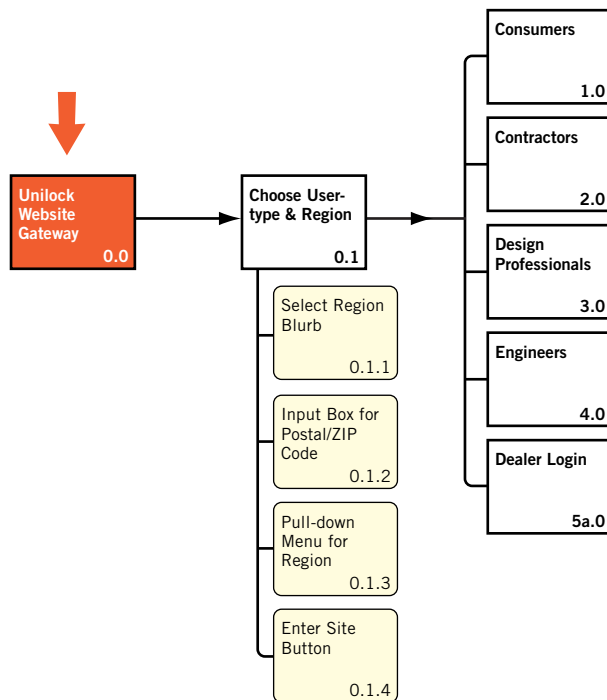

0.1 Choose User-type & Region

The Gateway page lists the five categories of Unilock website visitors: *Consumers*, *Contractors*, *Design Professionals*, *Engineers*, and *Dealers*.

This sequence prompts the user to select their user-type and region.

0.1.1 Select Region Blurb

Prompts the visitor to select a region.

0.1.2 Input Box for Postal/ZIP Code

The visitor may specify their region by entering their postal/ZIP code. Postal codes with and without spaces are valid.

0.1.3 Pull-down Menu for Region

Alternatively, the visitor may choose a region from a pull-down menu. The user may also select “All Regions”. The default text in the menu is “Select Region”.

If “All Regions” is selected, local promotions will not be available on the *User-type Homepages*. Instead, some sort of tip or general promotion will be shown (*to be determined*). Visitors can still find out about local promotions through *Events and Seminars* (8.0).

0.1.4 Enter Site Button

Submits the form and takes user to the appropriate section, storing their region information. If the user clicks the button without entering a postal/ZIP code or selecting a region, they will enter the site as though they had chosen “All Regions”.

1.0 Consumers Homepage

This section is dedicated to Unilock's consumer customers. It contains information that is specifically relevant to consumers such as do-it-yourself seminars, consumer promotions, and tips on hiring a contractor.

1.0.1 Consumers Opener

An introductory device that serves to capture the visitor's attention and bring them into the section. This device can be an introductory blurb, graphic, or animation.

1.0.2 Featured Promotion/Event

A teaser for a promotion/event that is running in the visitor's area (if the visitor has entered that information). The teaser links to the corresponding *Event Detail* page (8.1.1) within *Events & Seminars* (8.0).

1.0.3 Installation of the Month

A teaser for a monthly showcase of a Unilock installation. The teaser links to the corresponding *Installation of the Month* page (6.6) within *Design Ideas* (6.0).

1.0.4 News

A list of the two or three most recent news headlines in *News* (10.2). May also include events and promotions.

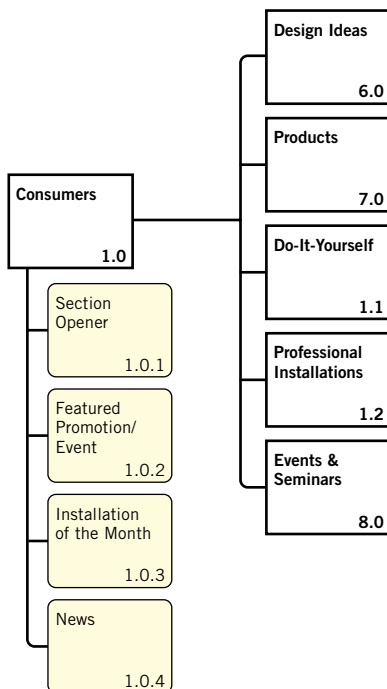

1.1 Do-It-Yourself

This section helps consumers design & install their own Unilock projects.

1.1.0.1 DIY Blurb

An introductory blurb that talks about the ease and rewards of installing a Unilock project.

1.1.1 Laying Patterns

An index of laying patterns. The index takes the form of a list of pavers that is divided into *Textured*, *Standard*, *Industrial*, and *Environmental* pavers. The visitor can also choose to *View All Patterns*.

There may be a section toward the end of the index on making circles or other, more specialized, patterns such as those achieved using *Paver Quilting* (1.1.1.2).

Ideally, people should be able to see photographs of installations that use the patterns being shown. If this were to be the case, the installations would be shown in a manner similar to the *Design Ideas Gallery* (6.x.1).

1.1.1.1 Patterns

This page is similar to the laying patterns page in the current Unilock site, but it only shows the patterns for a given paver. If a pattern is complex, it could link to an additional page that provides more explicit instructions on the placement of the different paver sizes.

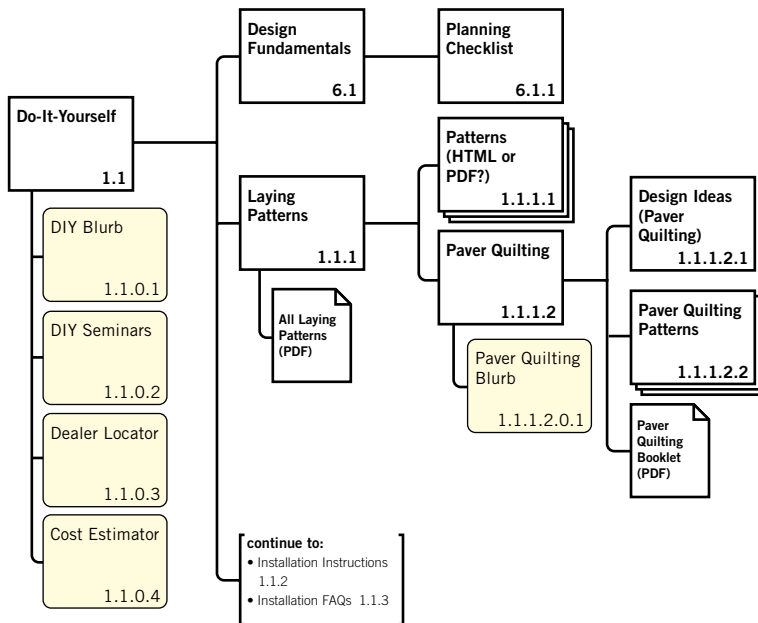

1.1 Do-It-Yourself : 1.1.1 Laying Patterns (cont'd)

1.1.1.2 Paver Quilting

An introductory blurb that talks about Paver Quilting. Unilock products that are designed for Paver Quilting are listed with the product names linking to the appropriate product detail pages.

1.1.1.2.0.1 Paver Quilting Blurb

An introductory blurb explaining Paver Quilting. Contains links to a PDF of the *Paver Quilting Booklet* and the *Order Literature & Videos* (12.4) page.

1.1.2.2.1 Design Ideas (Paver Quilting)

A Design Ideas Gallery that shows installations that use Paver Quilting.

1.1.2.2.2 Paver Quilting Patterns

A collection of Paver Quilting patterns.

1.1.2.2.3 Paver Quilting Booklet

A PDF of the Paver Quilting Booklet. The user may also choose to order a booklet. The link & information should be incorporated into the *Paver Quilting Blurb* (1.1.1.2.0.1).

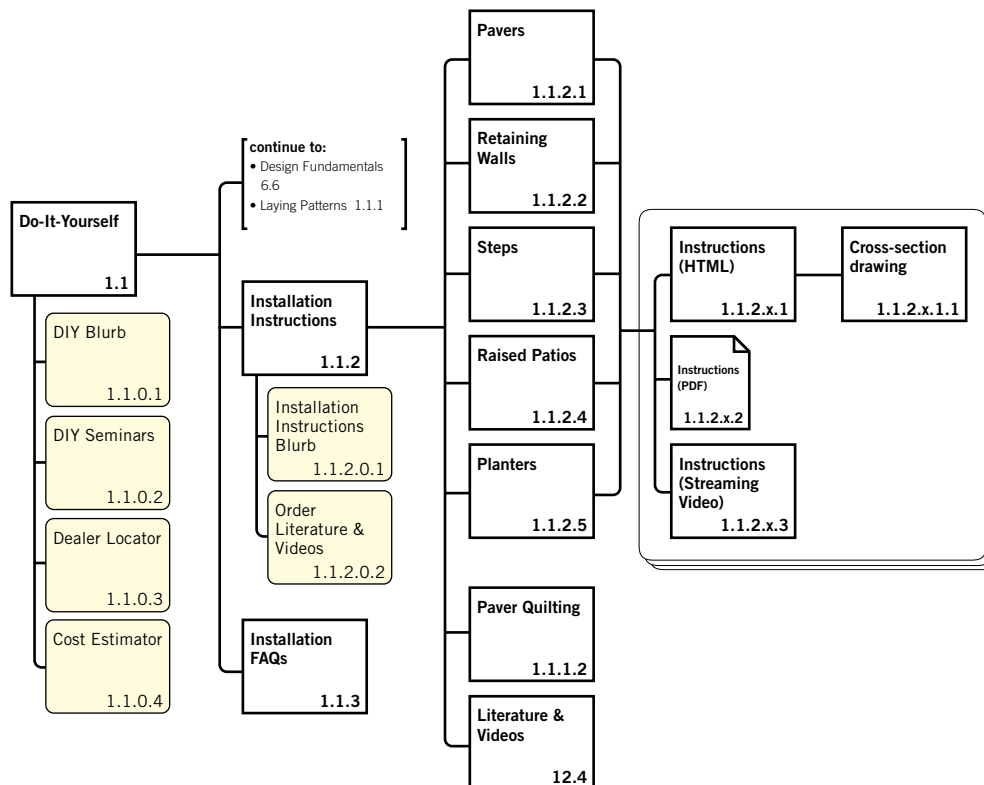

1.1 Do-It-Yourself (cont'd)

1.1.2 Installation Instructions

This section contains instructions for a variety of projects. These instructions may be presented using *PDFs* (1.1.2.x.2) and/or *HTML* pages (1.1.2.x.1). *HTML* pages are worthwhile simply because they allow visitors to browse more easily. For example, there is no need for the user to download the entire document & there is no extra software that needs to start up to get at the information. *Streaming video* (1.1.2.x.3) is also available.

Beside each project-type, the availability of *HTML*, *PDF*, and video installation instructions is shown.

An introductory blurb can mention *Paver Quilting* (1.1.1.2) and indicate that visitors can *Order Literature & Videos* (12.4).

If no *HTML* instruction pages are offered, all installation instructional *PDFs* (1.1.2.x.1.1) and *videos* (1.1.2.x.3) are listed on a single page.

1.1.2.1 Instructions – Pavers

Step-by-step instructions for installing pavers. The first page might contain an overview of the stages involved (i.e., planning & design [refer to Laying Patterns, Design Ideas, and Planning Checklist], base preparation [excavation, compacting the gravel base, screeding], laying & cutting [laying, cutting], finishing [edge restraints, compacting the pavers, jointing sand]).

1.1.2.2 Instructions – Retaining Walls

Step-by-step instructions for installing retaining walls. The first page might contain an overview of the stages involved (i.e., planning & design, base preparation, laying, backfilling, coping).

1.1.2.3 Instructions – Steps

An introductory blurb explains that step construction is similar to wall construction. The stages of wall construction are covered.

1.1.2.4 Instructions – Raised Patios

An introductory blurb explains that raised patio construction uses both wall construction and paver installation. The stages of raised patio construction are covered.

1.1.2.5 Instructions – Planters

An introductory blurb explains that step construction is similar to wall construction. The stages of planter construction are covered.

1.1.3 Installation FAQs

This section contains frequently asked questions of interest to do-it-yourselfers.

1.2 Professional Installations

This section helps consumers find and hire a professional to design or install their Unilock project.

1.2.0.1 Professional Installations Blurb

An introductory blurb that talks about the Unilock Authorized Contractor (UAC) Program. The blurb could also mention the *Cost Estimator* (16.0) and ask if the visitor would like to *Request a Free Estimate* (17.0).

1.2.0.2 Code of Ethics

The *Code of Ethics* that UAC's must adhere to.

1.2.0.3 Comparing Quotations

Teaser/link for *Comparing Quotations* (1.2.1) in Professional Installations Blurb.

1.2.0.4 Cost Estimator

Teaser/link for *Cost Estimator* (16.0) in Professional Installations Blurb.

1.2.0.5 Request a Free Estimate

Teaser/link for *Request a Free Estimate* (17.0) in Professional Installations Blurb.

1.2.1 Comparing Quotations

Tells consumers how to meaningfully compare contractor quotations. Provides a list of questions to ask the contractor and explains why they are important. The *Professional Installation Blurb* (1.2.0.1) points to the “Be Paver Wise” brochure (PDF) as another source of information on comparing contractor quotations.

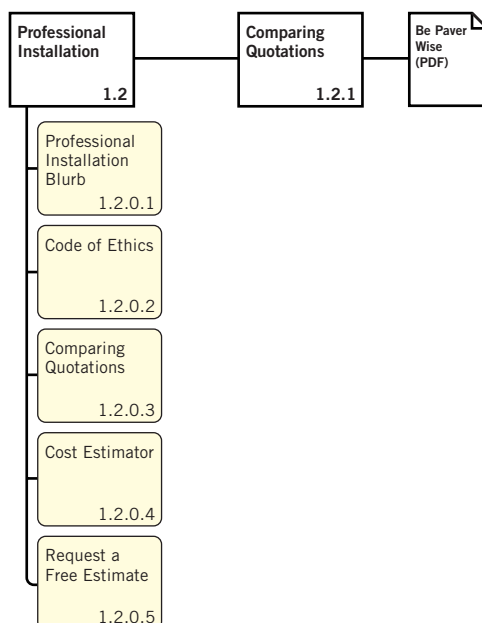

2.0 Contractors Homepage

This section is dedicated to contractors. It contains information that is specifically relevant to contractors such as the Unilock Authorized Contractor Program and contractor seminars.

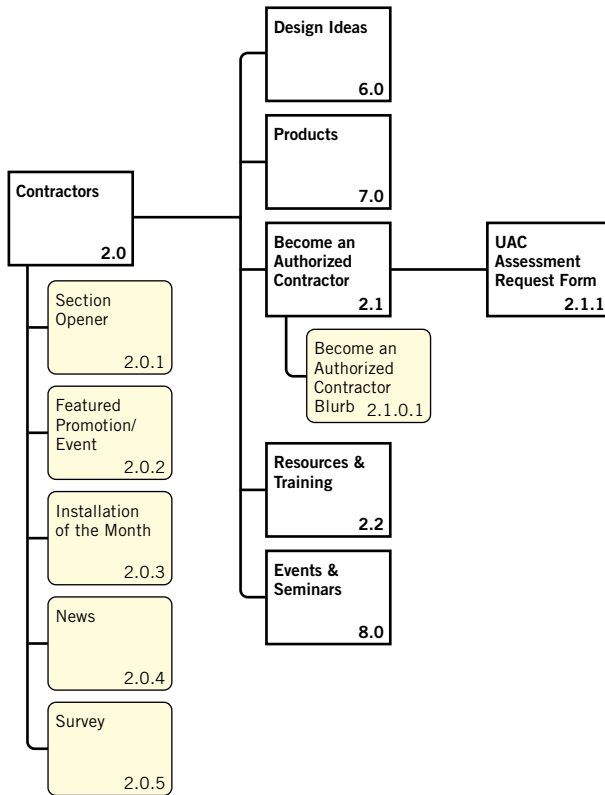

2.0.1 Contractors Opener

An introductory device that serves to capture the visitor's attention and bring them into the section. This device can be an introductory blurb, graphic, or animation.

2.0.2 Featured Promotion/Event

A teaser for a promotion/event that is running in the visitor's area (if the visitor has entered that information). The teaser links to the corresponding *Event Detail* page (8.1.1) within *Events & Seminars* (8.0).

2.0.3 Installation of the Month

A teaser for a monthly showcase of a Unilock installation. The teaser links to the corresponding *Installation of the Month* page (6.6) within *Design Ideas* (6.0).

2.0.4 News

A list of the two or three most recent news headlines in *News* (10.2). May also include events and promotions.

2.1 Become an Authorized Contractor

This section tells contractors how to become Unilock Authorized Contractors (UACs).

2.1.0.1 Become an Authorized Contractor Blurb

An introductory blurb that talks about the Unilock Authorized Contractor Program: its benefits and requirements. Provides an overview of the process involved in becoming an Authorized Contractor and links to the *UAC Assessment Request Form* (2.1.1).

2.1.1 UAC Assessment Request Form

A form to request a free assessment and consultation about becoming a UAC.

2.2 Resources & Training

This section contains resources & tools for contractors. It will consist of resources that can be used online (e.g., product literature [PDF or HTML]), material that can be downloaded for use (e.g., product literature PDFs, quotation software), and material that can be ordered (e.g., product literature, paver samples, promotional materials, CD-ROMs, and software). It may also contain online applications such as the *Risi search application* (19.0).

The resources and tools in this section should be grouped into categories to help visitors quickly find the information they are looking for.

Content to be determined.

3.0 Design Professionals Homepage

This section is dedicated to design professions (e.g., garden designers, landscape architects, architects). It contains information that is specifically relevant to design professionals such as cross-sectional drawings. While the information contained in this section is virtually identical to that in *Engineers* (4.0), it's marketing strategy is specifically geared towards the design community.

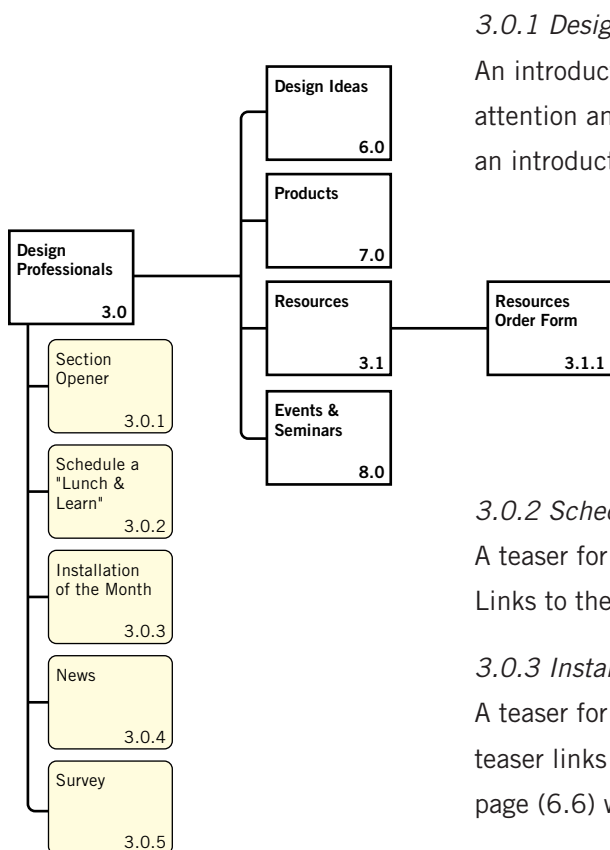

3.0.1 Design Professionals Opener

An introductory device that serves to capture the visitor's attention and bring them into the section. This device can be an introductory blurb, graphic, or animation.

3.0.2 Schedule a "Lunch & Learn"

A teaser for a "Lunch & Learn" presentation from Unilock. Links to the corresponding *Event Detail* page (8.1).

3.0.3 Installation of the Month

A teaser for a monthly showcase of a Unilock installation. The teaser links to the corresponding *Installation of the Month* page (6.6) within *Design Ideas* (6.0).

3.0.4 News

A list of the two or three most recent news headlines in *News* (10.2). May also include events and promotions.

3.1 Resources

This section contains resources & tools for design professionals. It consists of resources that can be used online (e.g., product literature [PDF or HTML], Risi search application), material that can be downloaded for use (e.g., Risi Wall software, PC SWMM software), and material that can be ordered (e.g., product literature, paver samples, promotional materials, CD-ROMs, and software). Ordering or downloading resource material may require the visitor to enter some personal information so Unilock can build a database of users. Visitors may also choose to subscribe to Unilock's e-mail update.

The resources and tools in this section should be grouped into categories to help visitors quickly find the information they are looking for.

Content to be determined.

4.0 Engineers Homepage

This section is dedicated to engineering professions. While the information contained in this section is virtually identical to that in *Design Professionals* (3.0), its marketing strategy is specifically geared towards the engineering community.

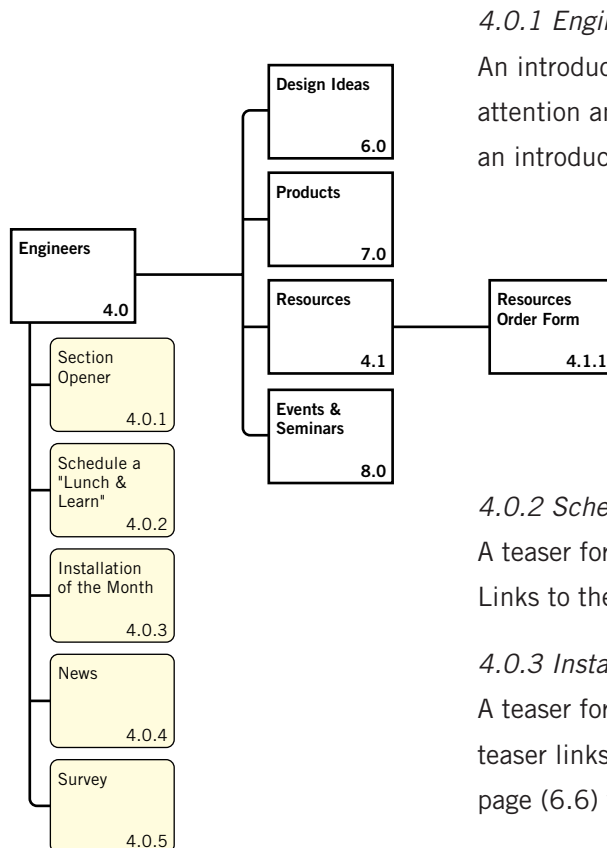

4.0.1 Engineers Opener

An introductory device that serves to capture the visitor's attention and bring them into the section. This device can be an introductory blurb, graphic, or animation.

4.0.2 Schedule a "Lunch & Learn"

A teaser for a "Lunch & Learn" presentation from Unilock. Links to the corresponding *Event Detail* page (8.1).

4.0.3 Installation of the Month

A teaser for a monthly showcase of a Unilock installation. The teaser links to the corresponding *Installation of the Month* page (6.6) within *Design Ideas* (6.0).

4.0.4 News

A list of the two or three most recent news headlines in *News* (10.2). May also include events and promotions.

4.1 Resources

This section contains resources & tools for design professionals. It consists of resources that can be used online (e.g., product literature [PDF or HTML], Risi search application), material that can be downloaded for use (e.g., Risi Wall software, PC SWMM software), and material that can be ordered (e.g., product literature, paver samples, promotional materials, CD-ROMs, and software). Ordering or downloading resource material may require the visitor to enter some personal information so Unilock can build a database of users. Visitors may also choose to subscribe to Unilock's e-mail update.

The resources and tools in this section should be grouped into categories to help visitors quickly find the information they are looking for.

Content to be determined.

5.0 Dealer Homepage

This section is dedicated to Unilock's dealer community. It houses a password-protected area that contains display ideas and promotion materials for dealers' use.

5.0.1 Dealer Opener

An introductory device that serves to capture the visitor's attention and bring them into the section. This device can be an introductory blurb, graphic, or animation.

5.0.2 Dealer Code Input Box

Input box for a registered dealer's code/user ID.

5.0.3 Dealer Password Input Box

Input box for a registered dealer's password.

5.0.4 Submit Button

Submits form. If the dealer ID and password are valid, the *Dealer Support* page (5.2) is loaded. If the ID and password are invalid, the *Login Error* page (5.1.3) is loaded.

5.0.5 Recent News Items

A list of the two or three most recent news headlines in *News* (10.2). May also include events and promotions.

5.0.6 Dealer Support

A teaser for the password-protected *Dealer Support* (5.2) material. The *Dealer Login* page (5.1) is loaded if a visitor has not logged in and attempts to enter the *Dealer Support* (5.2) section.

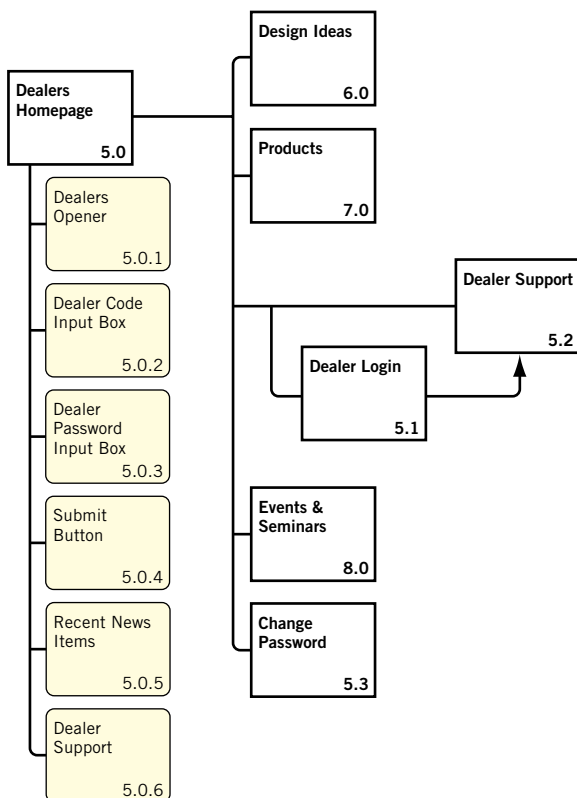

5.1 Dealer Login

This page is loaded if a visitor attempts to enter the *Dealer Support* section (5.2) before logging in.

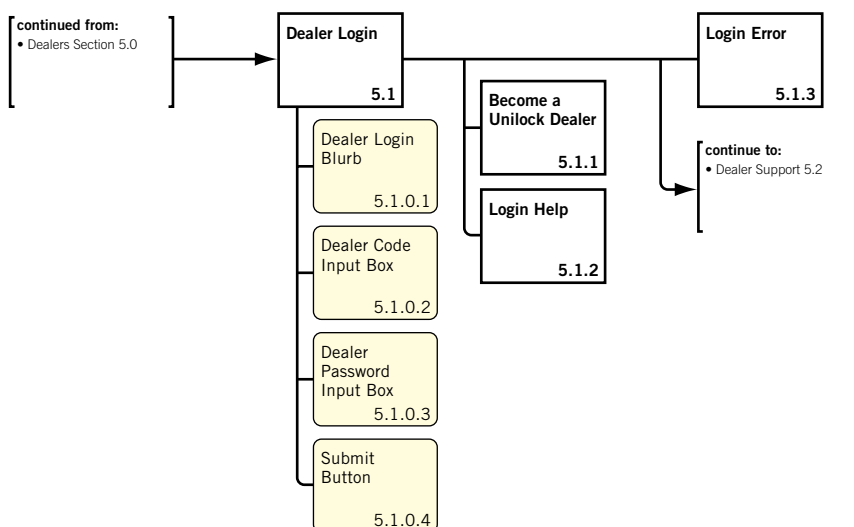

5.1.0.1 Dealer Login Blurb

This blurb instructs registered Unilock dealers to enter their dealer ID and password to enter the *Dealer Support* section (5.2) of the website. These instructions are followed by a link to *Login Help* (5.1.2).

Beneath the login input boxes, there is an introductory blurb that talks about the Dealer Section of the Unilock website. The goal of this blurb is to compel dealers to register & use this section of the website. It contains a link to *Become a Unilock Dealer* (5.1.2).

5.1.0.2 Dealer Code Input Box

Input box for a registered dealer's code/user ID.

5.1.0.3 Dealer Password Input Box

Input box for a registered dealer's password.

5.1.0.4 Submit Button

Submits form. If the dealer ID and password are valid, the *Dealer Support* page (5.2) is loaded. If the ID and password are invalid, the *Login Error* page (5.1.3) is loaded.

5.1.1 Become a Unilock Dealer

Provides information on how to become a Unilock dealer. It may contain, or link to, a form similar to *UAC Assessment Request Form* (2.1.1). If the introductory blurb about the Dealer Section of the site is too cumbersome for the *Dealer Login* page (5.1.0), that information may be placed in this section.

5.1.2 Login Help

A section containing instructions on what to do about forgotten IDs and passwords. There could also be a link to *Become a Unilock Dealer* (5.1.1).

5.1.3 Login Error

When the dealer ID or password are incorrect, this page is loaded. It highlights the error and prompts the user to enter the correct information. Links are also provided to *Become a Unilock Dealer* (5.1.1) and *Login Help* (5.1.2).

- Display Ideas
- Unilock TV Ads
- Literature & Product Data
- Dealer TV Ads
- Radio Ads
- Unilock Apparel
- Advertising Graphics

5.2 Dealer Support

A list of support material for dealers:

The resources in this section should be grouped into categories to help visitors quickly find the information they are looking for.

Content to be confirmed.

5.3 Change Password

This page allows dealers to change their password. If dealers have other information stored on the website, they might be able to edit it on this page as well.

6.0 Design Ideas

This section contains a collection of galleries containing photographs of outstanding Unilock installations. Users can browse the various galleries to see the breadth of applications that Unilock products are used in. This section can also be used as an aide to the creative process – providing inspiration for visitors’ own projects.

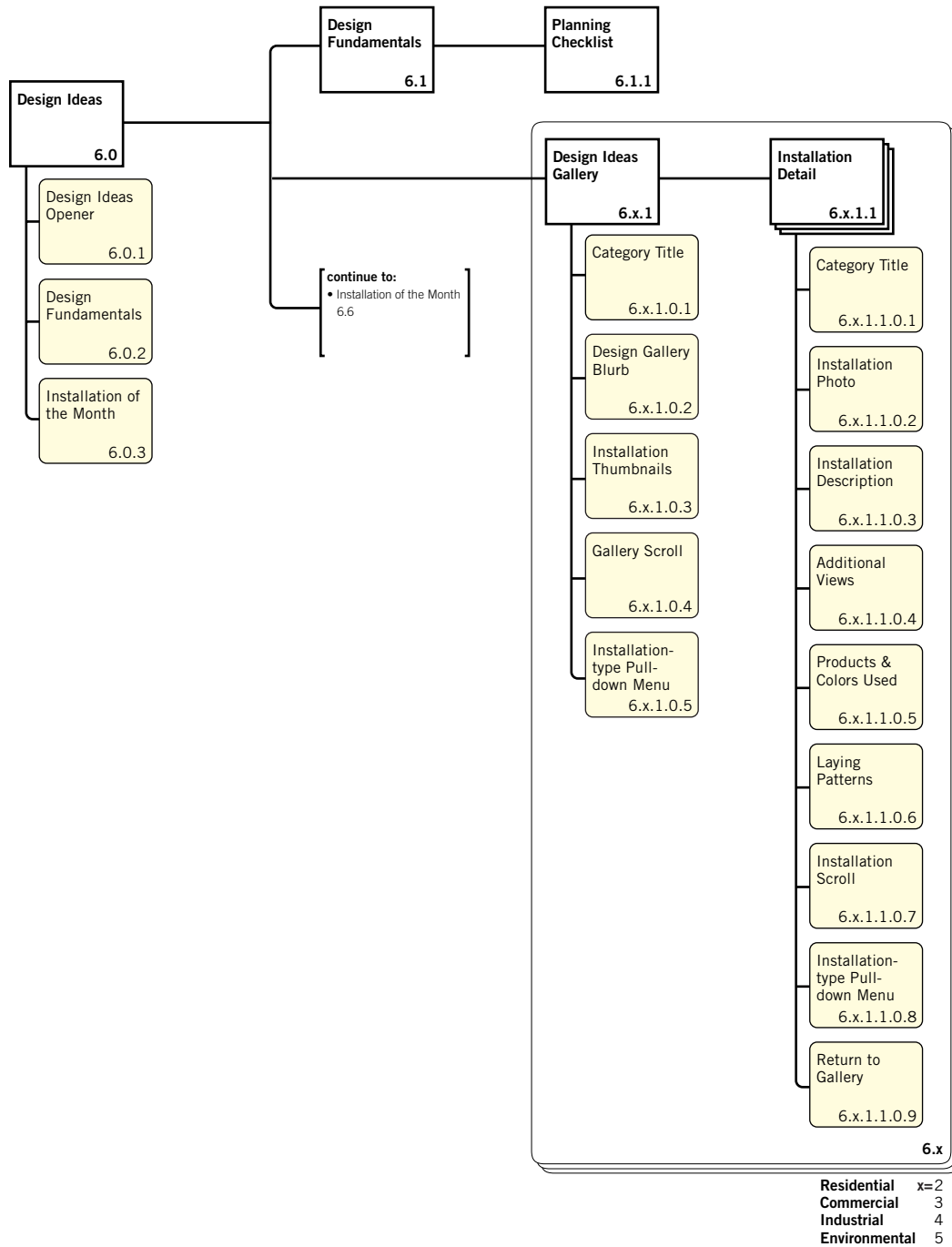

6.0 Design Ideas (cont'd)

6.0.1 Design Ideas Opener

An introductory device that serves to capture the visitor's attention and bring them into the section. This device can be an introductory blurb, graphic, or animation.

6.0.2 Design Fundamentals

A teaser for the *Design Fundamentals* section (6.1).

6.0.3 Installation of the Month

A teaser for a monthly showcase of a Unilock installation. The teaser links to the corresponding *Installation of the Month* page (6.6) within *Design Ideas* (6.0).

6.1 Design Fundamentals

A primer on landscape design as it pertains to the use of Unilock products. It would likely contain some sort of an introductory blurb. The information could be presented on one page or, if necessary, as a number of articles. This information is also presented in *Do-It-Yourself* (1.1).

The installations are divided into four categories: *Residential* (6.2) , *Commercial* (6.3) , *Industrial* (6.4), and *Environmental* (6.5).

6.2 Residential

Galleries of residential projects broken down into the following sub-categories:

- a. Driveways
- b. Entrances
- c. Patios
- d. Pools
- e. Steps
- f. Special Features

6.3 Commercial

Galleries of commercial projects broken down into the following sub-categories:

- a. Golf Courses
- b. Institutional
- c. Municipal
- d. Parks
- e. Plazas
- f. Special Features

6.4 Industrial

Galleries of industrial projects broken down into the following sub-categories:

- a. Driveways
- b. Roadways
- c. Parking Areas

6.5 Environmental

Galleries of environmental projects broken down into the following sub-categories:

- a. Parking Areas
- b. Retention Ponds
- c. Spillways

Each of the four categories contain *Design Ideas Gallery* pages (6.x.1) and *Installation Detail* pages (6.x.1.1). These pages are described below.

6.x.1 Design Ideas Gallery

Gallery pages are used to browse the installations found within Design Ideas. They show a collection of thumbnail photographs of installations.

6.x.1.0.1 Category Title

The name of the current Design Ideas category (e.g., Residential, Commercial, etc.). If this is a Product Installation Detail, the name of the product is shown (e.g., Brussels Block, Olde Greenwich Cobble, etc.).

6.x.1.1.0.2 Design Gallery Blurb

If desired, a blurb can be placed on design gallery pages. It could list the types of projects in the selected category, suggest how to use the *Design Ideas* section, or offer a design tip. It could be the same on every page or it could draw upon a pool of blurbs.

6.x.1.0.3 Installation Thumbnails

Between 6 and 10 thumbnail installation images (in the range of 130 px × 110 px) per page. Additional images would be housed within additional gallery pages. Visitors can click on thumbnails to get to the *Installation Detail* page (6.x.1.1).

6.x.1.0.4 Gallery Scroll

Visitors can use this device to page to the previous and next installations in the category. There is a notation that tells the visitor the number of the installation they are on relative to the total number of installations in the category.

6.x.1.0.5 Installation-type Pull-down Menu

Visitors can use this pull-down menu as a shortcut to the different sub-categories (e.g., Driveways) in the current category (e.g., Residential). *All installations* within the category are shown if the visitor does not select a sub-category. This will occur if the visitor enters the *Design Gallery* from the *Site Map* (11.0).

6.x.1.1 Installation Detail

This page contains a larger photo of the installation and information about some of the installation specifics. From this page visitors can page back and forth to adjacent installations in the gallery.

6.x.1.1.0.1 Category Title

The name of the current Design Ideas category (e.g., Residential, Commercial, etc.). If this is a Product

Installation Detail, the name of the product is shown (e.g., Brussels Block, Olde Greenwich Cobble, etc.).

6.x.1.1 Installation Detail (cont'd)

6.x.1.1.0.2 Installation Photo

A larger version of the installation thumbnail shown on the *Design Ideas Gallery* page (6.x.1).

6.x.1.1.0.3 Installation Description

A paragraph or two about the installation: its function, why a particular look or style was chosen, technical considerations, etc.

6.x.1.1.0.4 Additions Views

Thumbnails of additional photos of the installation. This page component does not appear if additional photos are unavailable.

6.x.1.1.0.5 Products & Colors Used

A list of the products and colors used in the installation. Pavers would be listed separately from walls. The product names link to the corresponding *Product Detail* pages (7.x.1).

6.x.1.1.0.6 Laying Patterns

Lists the laying pattern(s) used in the installation. The name of the laying pattern links to the corresponding pattern on the appropriate *Patterns* page (1.1.1.1).

6.x.1.1.0.7 Installation Scroll

Visitors can use this device to page to the previous and next installations in the category. There is a notation that tells the visitor the number of the installation they are on relative to the total number of installations in the category.

6.x.1.1.0.8 Installation-type Pull-down Menu

Visitors can use this pull-down menu as a shortcut to the different sub-categories (e.g., Driveways) in the current category (e.g., Residential).

6.x.1.1.0.9 Return to Gallery

Visitors can return to the gallery page they entered from by using this link.

6.6 Installation of the Month

As an added draw to the website, an installation is featured each month. To distinguish the *Installation of the Month* from regular *Design Ideas Installations*, the *Installation of the Month* could show multiple photographs of the installation and provide more in-depth background information. As a value-added feature for designers, builders and contractors, the *Installation of the Month* feature could give some information about the professionals involved in the installation, including their contact information. Each *Installation of the Month* should have a short descriptive name associated with it. If desired, this type of expanded description could be applied to future additions to the *Design Ideas* gallery.

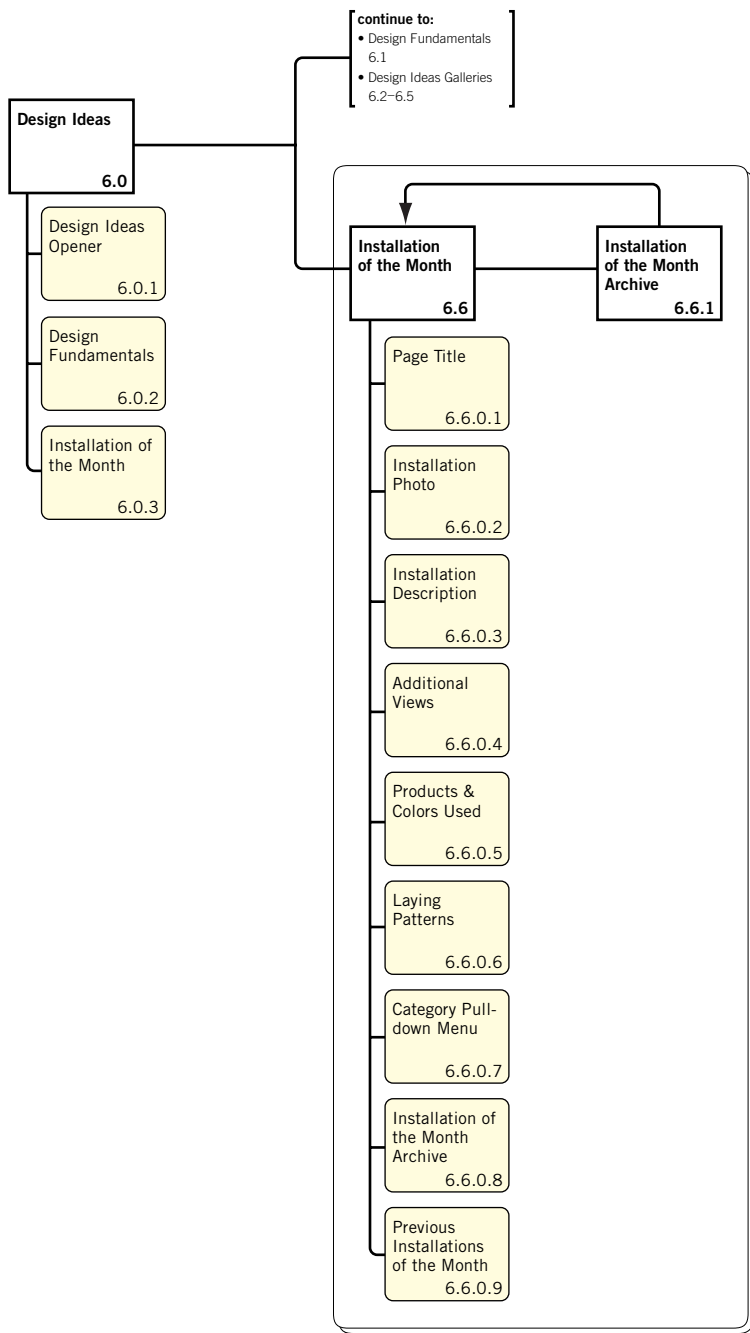

6.6 Installation of the Month (cont'd)

Each “builder” user-type category has a different *Installation of the Month*: consumer, contractor, design professional, and engineer. All *Installations of the Month* would be housed within this section. The only difference would be in the *Installation of the Month* shown on the *User-type Homepages*.

6.6.0.1 Page Title

The title of the displayed page. (i.e., *Installation of the Month*)

6.6 Installation of the Month (cont'd)

6.6.0.2 Installation Photo

A larger version of the installation thumbnail shown in the *Installation of the Month Teaser* shown on the various user-type homepages.

6.6.0.3 Installation Description

A paragraph or two about the installation: its function, why a particular look or style was chosen, technical considerations, etc. As a value-added feature for designers, builders, and contractors, the description could include information about the professionals involved in the installation, including their contact information.

6.6.0.4 Additional Views

Thumbnails of additional photos of the installation. This page component does not appear if additional photos are unavailable.

6.6.0.5 Products & Colors Used

A list of the products and colors used in the installation. Pavers would be listed separately from walls. The product names link to the corresponding *Product Detail* pages (7.x.1).

6.6.0.6 Laying Patterns

Lists the laying pattern(s) used in the installation. The name of the laying pattern links to the corresponding pattern on the appropriate *Patterns* page (1.1.1.1).

6.6.0.7 Category Pull-down Menu

Visitors can use this pull-down menu as a shortcut to the different sub-categories (e.g., Consumer) within *Installation of the Month*.

6.6.0.8 Installation of the Month Archives

Visitors can access the *Installations of the Month Archive* (6.6.1) using this link.

6.6.0.9 Previous Installations of the Month

A short-list of (3) previous Installations of the Month. It is simply a list of installation names. There is also a link to the *Installation of the Month Archive* (6.6.1).

6.6.1 Installation of the Month Archive

An index of past *Installations of the Month*, listed chronologically from most to least recent. No date information is shown in the index.

7.0 Products

This section contains information about Unilock's entire suite of products.

7.0.1 Products Opener

An introductory device that serves to capture the visitor's attention and bring them into the section.

This device can be an introductory blurb, graphic, or animation. For the *Products* section, the opener could consist of concise marketing copy extolling the strengths of Unilock's product lines.

The products are divided into seven categories: *Textured Pavers* (7.1), *Standard Pavers* (7.2), *Industrial Pavers* (7.3), *Environmental Pavers* (7.4), *Garden Walls* (7.5), *Retaining Walls* (7.6), and *Accessories* (7.7).

7.1 Textured Pavers

- a. Brussels Block
- b. Il Campo
- c. Optika
- d. Series 3000
- e. Stonehenge
- f. Unigranite

7.2 Standard Pavers

- a. Bullnose Paver
- b. Camelot
- c. Classico
- d. Cortina
- e. Hollandstone
- f. Double Holland
- g. Half Holland
- h. Holland Edger
- i. Olde Greenwich Cobble
- j. Uni-Decor
- k. Uni-Stone

7.3 Industrial Pavers

- a. Anchorlock
- b. Optiloc
- c. Uni-Stone

7.4 Environmental Pavers

- a. Aquaterra
- b. Dura-Mat
- c. Ecoloc
- d. Turfstone
- e. Uni Eco-Stone

7.5 Garden Walls

- a. Brussels Dimensional Stone
- b. The Estate Wall
- c. Garden Stone
- d. Quarrystone
- e. Roman Stack
- f. Stack Stone
- g. Split 'N Stack

7.6 Retaining Walls

- a. Concord Wall
- b. Dura-Hold
- c. Dura-Hold2
- d. Pisa2
- e. Pisa Reversible
- f. Roman Pisa
- g. Roman Wall
- h. Siena Stone
- i. Slope Block Mk IV

7.7 Accessories

- a. Unilock Paver Sealant
- b. Unilock Effluorescence Remover
- c. Unilock Oil and Dirt Remover
- d. Unilock Rust Remover
- e. Unilock Paint, Tar, and Rubber Remover
- f. Unilock Polymeric Jointing Sand
- g. Unilock Joint Stabilizer Sealer
- h. Unilock Concrete Adhesive
- i. Unilock Edge Restraint
- j. Spikedge

7.x.1 Product Detail

The *Product Detail* page provides visitors with detailed information about Unilock products.

*Paver/Wall products only

**Accessory products only

7.x.1.0.1 Product Name

The name of the selected product.

7.x.1.0.2 Installation*/Product** Photo

The main installation/product photo on the page. For pavers & walls, clicking on the installation photo could take the visitor to the *Installation Detail* page (6.x.1.1) for that installation.

7.x.1.0.3 Product Description

A paragraph or two about the product.

7.x.1.0.4 Product Colors*

A list of the product colors available in the selected region. The visitor can see examples of the different colors by mousing over the color names.

If the user has not specified a region, a note appears in the *Product Colors* box saying, “Please select a region for accurate color information.”

Links are provided to take the visitor to the *Color Planner* (7.9) or the *Color Availability Chart* (PDF).

7.x.1.0.5 Unit Photos/Regional Availability*

Images of the paver/wall units, together with unit names and dimensions, available in the currently selected region. If the user has not specified a region, a note could appear saying, “Not all units are available in all regions. Please select a region to see available unit sizes,” followed by the *regional availability list* (7.x.1.0.5).

If the visitor accesses the product from an area where it is not available (i.e. using the *Product Pull-down Menu*), a note appears where the *unit photos* would usually appear that states that the chosen product is not available in the chosen region, followed by a list of regions where the product is available. Clicking on any of the region names loads the *Product Detail* page with the corresponding regional information.

7.x.1.0.6 Product Pull-down Menu*

Visitors can use this pull-down menu as a shortcut to all products on the Unilock site, regardless of regional availability. If a change is made, the new product page is loaded on selection. The menu shows, “Select Product”.

7.x.1.0.7 Region Pull-down Menu*

Visitors can change their regional information using this pull-down menu. If a change is made, the page is refreshed with new region-specific information on selection. If possible, only the regions that offer the product are listed in the menu.

7.x.1 Product Detail (cont'd)

7.x.1.1 Product Design Ideas Gallery

This link takes visitors to a *Design Ideas Gallery* page that is populated with thumbnail photos of installations that use the current product. The installations are sorted by installation-type (as in the regular *Design Ideas Gallery* [6.x.1]) and the different installation-types are accessed using a pull-down menu. *All Installations* are shown by default.

7.x.1.2 Product Literature

PDF versions of product-related literature. E.g., Product Specifications, MSDS Sheet**, Instructions, Laying Patterns*, etc.

7.8 Product Specifications

This section is simply an index of PDF product specification sheets. The spec sheets should be grouped in the same product categories used for the rest of the product section.

7.9 Color Planner

This feature may appear in its own window. (Requires some usability testing.) Its purpose is to help visitors determine the color palette for their project. Product colors are region-specific. If users have not specified a region, they are prompted to do so. If they have specified a region, their selected region is shown on the page. Region-related items (7.9.0.2–5) are always present on the screen.

There are three swatches that users can manipulate. The color shown for each swatch is controlled independently of the other swatches using drop-down menus.

7.9.0.1 Color Planner Opener

An introductory device that serves to capture the visitor's attention and bring them into the section. This device can be an introductory blurb, graphic, or animation. For this page, the opener tells visitors what the purpose of the *Color Planner* is and how to use it.

7.9.0.2 Select Region Prompt

If users have not specified a region, they are prompted to do so. If they *have* specified a region, their selected region is shown here.

7.9.0.3 Postal/ZIP Code Input Box

The visitor may specify their region by entering their postal/ZIP code. If they have already entered a postal or ZIP code, it is shown in the input box.

7.9.0.4 Region Pull-down Menu

Alternatively, the visitor may choose a region from a pull-down menu.

7.9.0.5 Choose Region Button

Submits the visitor's region selection. Color swatch information (7.9.0.7–9) is retained.

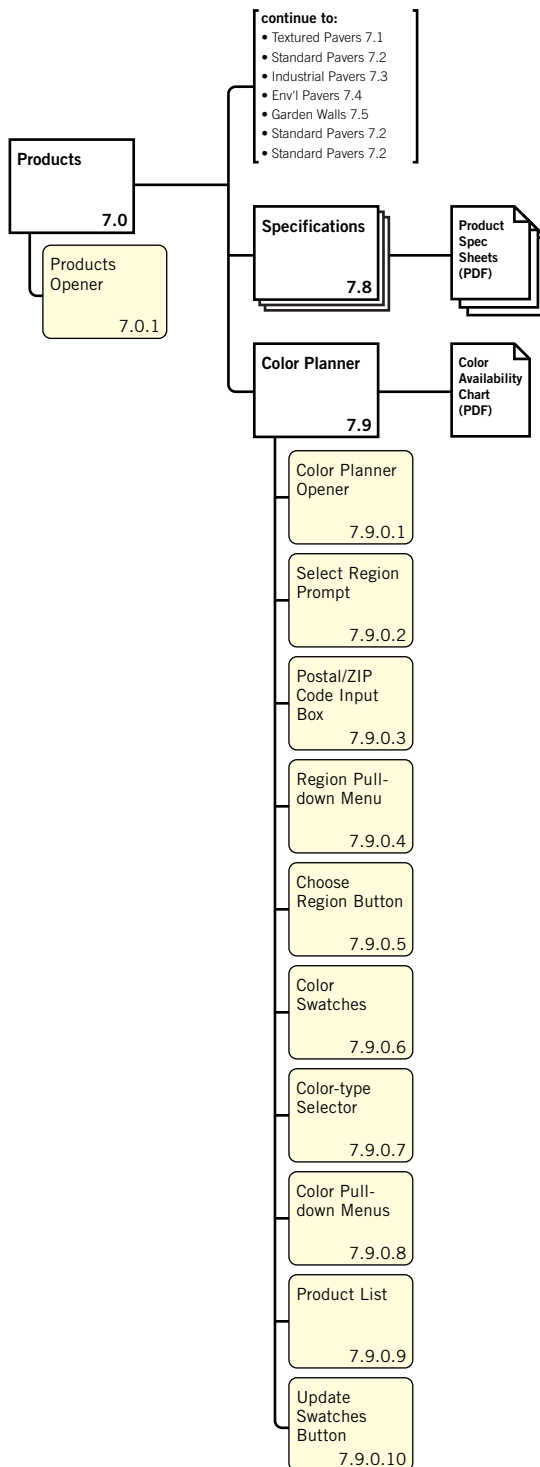

7.9 Color Planner (cont'd)

7.9.0.6 Color Swatches

Three color swatches are shown. The color shown for each swatch is controlled independently of the other swatches. A caption shows the name of the product shown in the swatch.

7.9.0.7 Color-type Selector

Allows users to select the type of colors shown in each swatch: Paver, Wall, or Building. The selection here determines which colors are available in the *Color Pull-down Menus* (7.9.0.8). Users must chose a color-type before being allowed to select a color.

7.9.0.8 Color Pull-down Menus

Allows users to select swatch colors. The colors shown in the menu are determined by the *Color-type Selector* (7.9.0.7). The default drop-down menu selection is 'Select Color'. For each swatch, the pull-down menu is hidden until the user has chosen a color-type (7.9.0.7). Having the menu become visible after a color-type has been selected helps guide new users through the process of using the *Color Planner*.

7.9.0.9 Product List

A list of products available for the selected color. Clicking on a product's name loads the corresponding *Product Detail* page (7.x.1). A caption informs the user of this behaviour (e.g., Click on a product name for product information.). If the *Color Planner* occurs in a pop-up window, the *Product Detail* (7.x.1) page is loaded in the original window.

Update information on color selection (7.9.0.8).

7.9.0.10 Update Swatches Button

Updates the page with the correct color swatches and product list. Not necessary if a new swatch (and its corresponding product information) can be shown without having to reload the entire page.

8.0 Events & Seminars

This section contains information about Unilock-related events & seminars. The first page lets the user select various search criteria for the events they want to see listed.

8.0.1 Events & Seminars Opener

An introductory device that serves to capture the visitor's attention and bring them into the section. This device can be an introductory blurb, graphic, or animation.

8.0.2 Event Filter Pull-down Menus

These pull-down menus are used to filter the list of events shown to the user. Events may be filtered by *Event Type*, *Month*, *City*, *State/Province* or any combination of these. The default setting is to show all events (i.e., no filtering takes place) for the visitor's region. If the visitor has not selected a region, events for all regions are shown. The visitor may use the *City* or *State/Province* pull-down menus to show events in their area.

Depending on the number of different types of events available, the *Event Type* classification could be broad (e.g., *Consumer*, *Professional*, *Special Events*, etc.) or specific (e.g., *DIY Seminars*, *Advanced Training Seminars*, *Segmental Retaining Wall Seminars*, *Promotions*, *Contests*, etc.)

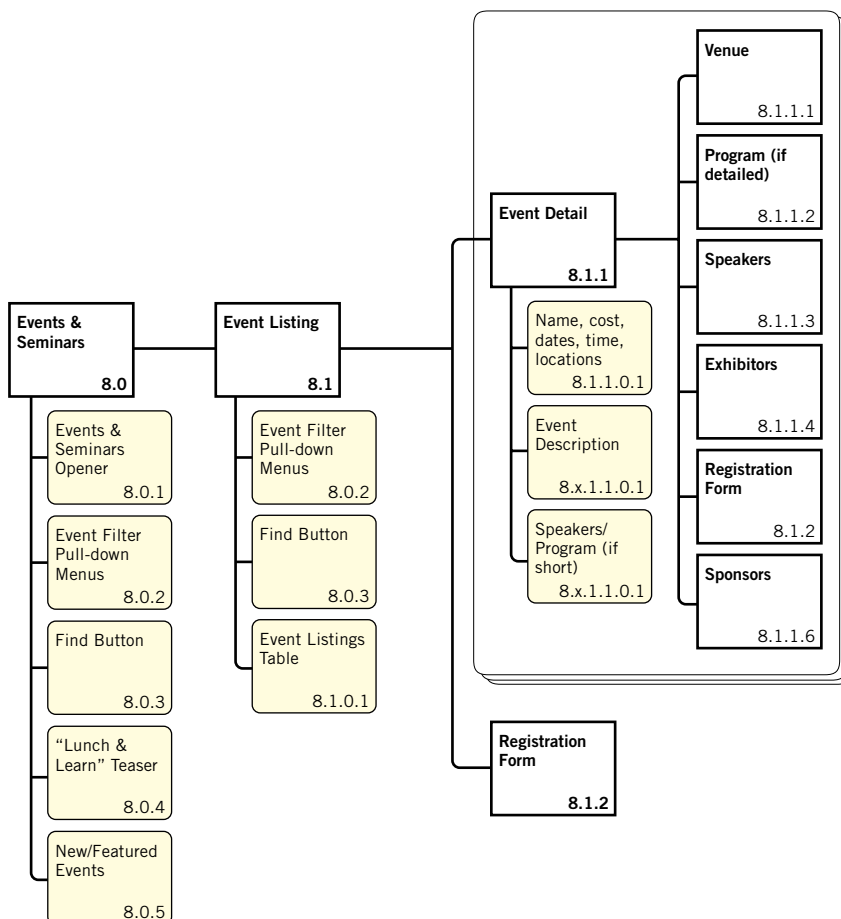

8.0 Events & Seminars (cont'd)

8.0.3 Find Button

Applies the location and event filtering criteria entered by the user. When the page information is refreshed (i.e., the *Event Listing* page (8.1) is loaded), the pull-down menus reflect the user's current filtering settings. There could also be a "Show All Events" button that loads a complete event listing

8.0.4 "Lunch & Learn" Teaser*

A teaser for a "Lunch & Learn" presentation from Unilock. Links to the corresponding *Event Detail* page (8.1).

*only in *Design Professionals* (3.0) and *Engineers* (4.0)

8.0.5 New/Featured Events

Space is available for new and/or featured events to be highlighted. The notice can take the form of the promotion shown in the sample *Consumer Homepage* or it can take the form of a text blurb as shown in the sample *Events & Seminars* page.

8.1 Event Listing

The *Event Listing* page lists events according to the criteria entered by the user.

8.1.0.1 Event Listings Table

The table headings are *Event Name*, *Date & Time*, *City*, *State/Prov*, and *Cost*.

The user may choose to sort the list of events by name, date, or location. By default, the list is primarily sorted alphabetically (a–z) by *Event Name*, then chronologically (sooner–later) by *Date*, then alphabetically (a–z) by *State/Province* then *City*. Users may change the primary sorting criterion by clicking on the appropriate table heading. For example, clicking on the heading *State/Province* would primarily sort the list alphabetically (a–z) by *State/Province*, followed by *City*, *Event Name*, then *Date*.

Each page shows a maximum of 15–20 listings. *Final number to be decided*.

If the user must register for an event, a *Register Button* is provided under the price of the event in the *Cost* column. Registration might be required if there is limited enrollment in an event or if there is a cost associated with it. The button takes the user to the *Registration Form* (8.1.2)

More information about an event can be seen by clicking on the event's name. This loads the corresponding *Event Detail* page (8.1.1). Short notes concerning an event may be placed below the event's name in the *Event Name* column.

8.1.1 Event Detail

The *Event Detail* page provides more information about an event.

8.1.1.0.1 Event Specs

Name, cost, date, time, and location.

8.1.1.0.2 Event Description

Description of the event.

8.1.1.0.3 Speakers/Program

Information about the event program and/or speakers if the information is brief.

The following sections/links may be added as needed (e.g., if the event is large).

8.1.1.1 Venue

Information about the event venue. (if detailed)

8.1.1.2 Program

Information about the event program. (if detailed)

8.1.1.3 Speakers

Short bios/info about the speakers

8.1.1.4 Exhibitors

Information about the exhibitors.

8.1.1.6 Sponsors

Information about the event sponsors/organizers.

8.1.2 Event Registration Form

Collects the information needed for a user to register for an event. *Content to be determined.*

9.0 Contact Us

This section helps visitors communicate with Unilock.

9.0.1 Contact Us Opener

An introduction to this section that expresses Unilock's commitment to effectively communicating with its customers and business partners. It may be used to direct visitors to the proper avenues for different varieties of enquires (e.g., feed back, request literature, request a quote, job hunting, ordering product, finding dealers, etc.)

9.0.2 Mailing Address

The mailing address of Unilock's head office. A link to *Regional Offices* (9.1) appears below this address or the toll-free number.

9.0.3 Toll-free Number

1-800-UNILOCK (1-800-864-5625).

9.0.4 E-mail Address

A universal e-mail address for general comments and feedback.

9.0.5 E-mail Form

A generic response form for comments. Also allows visitors to subscribe to Unilock's e-mail updates.

9.1 Regional Offices

This section lists all of Unilock's regional offices & their relevant contact information.

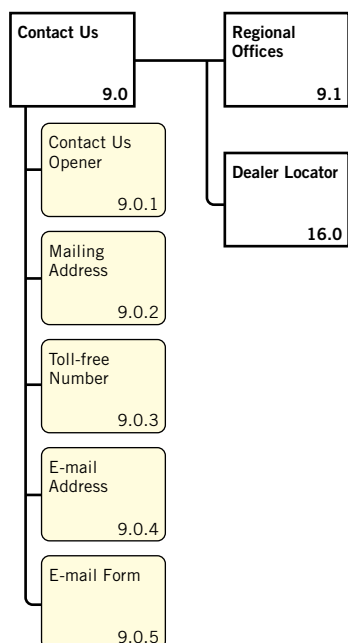

10.0 About Us

This section provides visitors with information about Unilock, the company. It contains a company profile, news items, and job opportunities. It could also contain sections on Unilock's history and management.

10.0.1 Recent News Items

A list of the three most recent news items in *News* (10.2). If only the titles are shown, this list may appear before the *Company Profile* (10.0.2). If short descriptions are associated with these items, however, this list should be placed after the *Company Profile*.

10.0.2 Company Profile

A company profile of Unilock. It might welcome the visitor to the website.

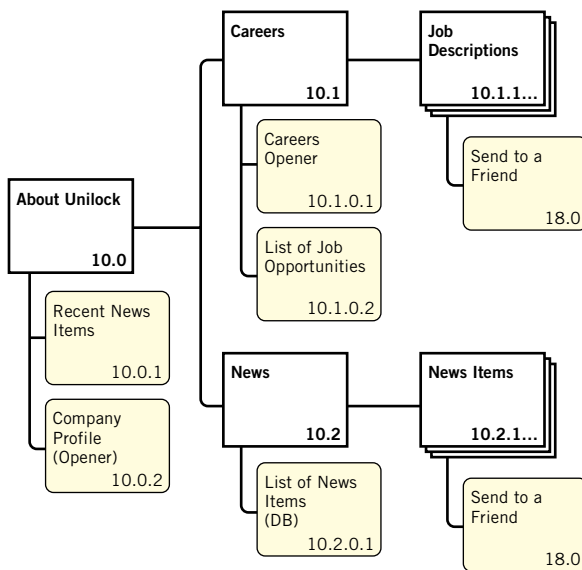

10.1 Careers

This section is used to recruit new employees for Unilock. It provides prospective employees with information about job opportunities, and it may also provide some insight into Unilock's company culture and benefits.

10.1.0.1 Careers Opener

An introduction to the Careers section. Tells prospective employees how to contact Human Resources at Unilock.

10.1.0.2 List of Job Opportunities

A list of job opportunities at Unilock that is initially organized by region. The list contains job title, department, and city.

At minimum, the list can be filtered/sorted by region. Ideally, the list can be filtered by department and city. It can also be sorted by job title, department, and city.

10.1 Careers (cont'd)

10.1.1... Job Description

The job titles could link to complete job descriptions that specify job responsibilities, necessary experience, etc. These job description pages may be sent to a friend (18.0).

10.2 News

This section contains news items pertaining to Unilock. These items (i.e., announcements, awards, press releases, etc.) cover all regions. Events such as promotions and contests are contained in *Events & Seminars* (9.0).

10.2.0.1 List of News Items

A chronological list of news item titles. The most recent items (1–3) may have short descriptions (up to 30 words) associated with them.

Show a maximum of 10 news item titles per page.

Each title links to the complete news item.

10.2.1... News Item

The complete text of the news item with optional, associated photo. These news item pages may be sent to a friend (18.0).

11.0 Site Map

This section serves as a table of contents for the site. A possible arrangement is shown below.

11.0.1 Company Information

- About Unilock
- Careers
- News

11.0.2 Contact Us

- Send Feedback
- Request Information
- Request a Free Quote
- Regional Offices

11.0.3 Design Ideas

- Design Fundamentals
- Residential
- Commercial
- Industrial
- Environmental
- Installation of the Month

11.0.4 Product Information

- Textured Pavers
- Standard Pavers
- Industrial Pavers
- Environmental Pavers
- Garden Walls
- Retaining Walls
- Accessories
- Product Specifications
- Color Planner

11.0.5 Events & Seminars

- DIY Seminars
- Contractor Seminars
- Design Seminars
- Engineering Seminars
- Promotions
- Other Events

11.0.6 Consumers

- Do-It-Yourself
- Installation Instructions
- Laying Patterns
- Professional Installations

11.0.7 Contractors

- Become a Unilock Authorized Contractor
- Resources & Training

11.0.8 Design Professionals

- Resources
- Schedule a Lunch & Learn Session (says Box Lunch presentation in USA)

11.0.9 Engineering

- Resources
- Schedule a Lunch & Learn Session (says Box Lunch presentation in USA)

11.0.10 Dealers (Password-protected)

- Become an Authorized Dealer

11.0 Site Map (cont'd)*11.0.11 Help*

Site Information
FAQs
Technical Assistance
Installation Instructions
Laying Patterns
Literature & Videos
E-mail Updates

11.0.12 Tools

Search
Risi Search
Color Planner
Dealer Locator
Cost Estimator

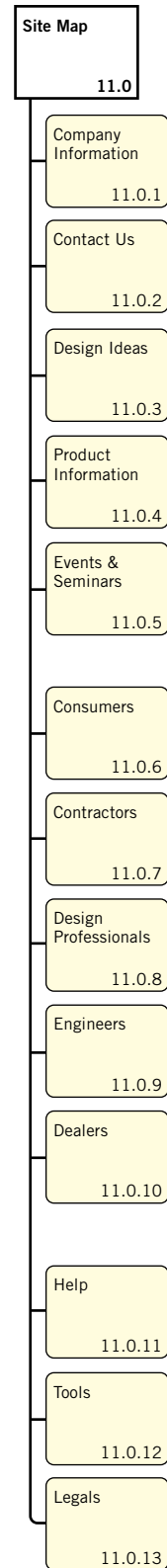
11.0.13 Legal Notices & Privacy Policy

12.0 Help

This section contains frequently asked questions and frequently sought information. It is a cross between a site help desk and a Unilock customer service centre.

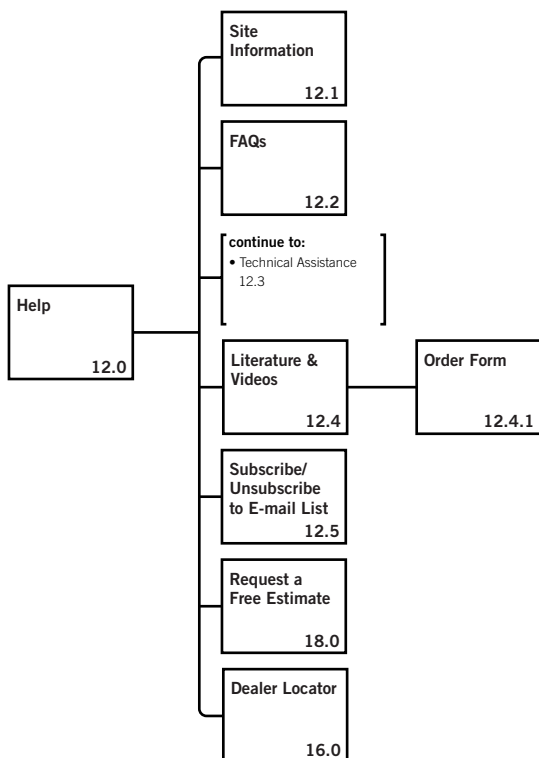

12.1 Site Information

This section contains information on the various technical aspects of the site. It might mention what level browsers the site is optimized to work with, optimal screen resolution & color depth, link to the Adobe Acrobat Reader, etc.

12.2 FAQs

This section contains frequently asked questions. Eventually, if the number of questions warrants it, the questions can be divided into different sections such as Installation FAQs, Dealer FAQs, Contractor FAQs, Maintenance & Repair FAQs, etc.

12.3 Technical Assistance

This section can be used by visitors to ask technical questions.

12.3.0.1 Response Form

Online form where visitors may submit questions, order material, request a free estimate, etc.

12.3.1 Installation Instructions

The content of this section is identical to *Installation Instructions* (1.1.2) in *Do-It-Yourself* (1.1).

12.3.2 Laying Patterns

The content of this section is identical to *Laying Patterns* (1.1.1) in *Do-It-Yourself* (1.1).

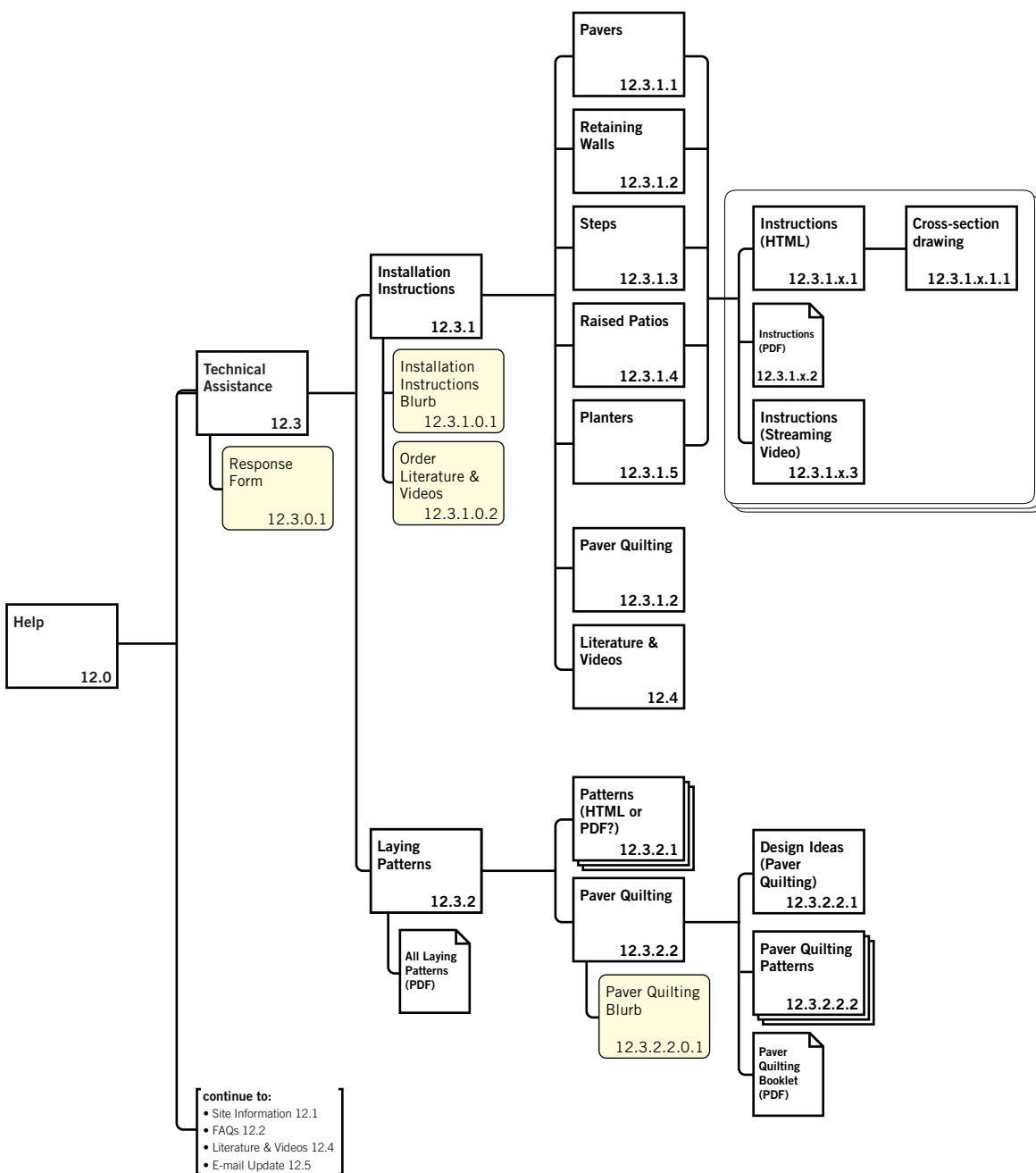

12.4 Literature & Videos

This section is a repository for all Unilock Literature & Videos. Free items may be available for download, while other items may be ordered using the *Order Form* (12.6.1). Descriptions are available for each item.

12.4.1 Order Literature & Videos

In addition to enabling visitors to order literature & videos from Unilock, this order form also offers visitors the opportunity to subscribe to Unilock's e-mail updates.

12.5 E-mail Updates

Visitors may subscribe or unsubscribe to Unilock's e-mail updates.

13.0 Legals

This section contains legal notices such as site terms & conditions, copyright information, and privacy policy.

MAIN FEATURES

14.0 Site Search

Users can use a keyword search to find information on the site.

14.1 Search Results

Content and layout depends on the search engine used. Limit number of hits per page so that user does not have to page down more than three or four times.

15.0 Dealer Locator

Enables a visitor to find a dealer in their vicinity.

15.0.1 Dealer Locator Blurb

Blurb on Unilock's extensive network of dealers.

15.0.2 Postal/ZIP Code Input Box

The visitor may choose to specify their region by entering their postal/ZIP code. If they have already entered a postal or ZIP code, it is shown in the input box.

15.0.3 Search Radius

A pull-down menu or input box for the user to specify the search area for the Dealer Locator.

15.0.4 Miles/KM toggle Radio Buttons

Enables users to specify whether the search radius is in miles or kilometres. (*May choose not to include this component in website*)

15.1 Special Orders

This page contains information on what to do if the visitor is outside Unilock's dealer network. Ultimately directs visitor to a phone number, e-mail address, and/or online response form.

16.0 Cost Estimator

Provides users with a rough estimate of the average cost of a project. The user is able to specify different project attributes. On the estimate results page, users may *Request a Free Estimate* (17.0). *Content to be determined.*

OTHER FEATURES

17.0 Request a Free Estimate

A response form requesting that Unilock send a contractor to provide an estimate for a project. *Content to be determined.*

18.0 Send to a Friend

Allows the visitor to send a page to someone's e-mail address. This functionality would typically be used on detail pages such as those for news items, jobs, events, installations, and products. Appears in a pop-up window.

18.0.1 Recipient's E-mail

Input box for recipient's e-mail address. *(Required)*

18.0.2 Sender's E-mail

Input box for sender's e-mail address. *(Required)*

18.0.3 Sender's Message

The sender may enter a message to be sent. *(Optional)*

18.0.4 Cancel Button

Closes pop-up window.

18.0.5 Send Button

Verifies that all required fields are valid and complete then sends page, or link to page, to the specified recipient. If there is an error, the fields with errors are flagged, a message states that there was an error and asks the user to re-enter the information.

18.0.6 Close Window Button

Closes pop-up window

18.1 "Send to a Friend" Confirmation

Confirms that message was sent.

18.1.1 Close Window Button

Closes pop-up window.

19.0 Risi Search

Allows the visitor to search a database of cross-sectional drawings for retaining wall construction.

20.0 Survey

The survey polls visitors on various issues. Visitors select their answer(s) and click on a *submit/vote button*. Their answer is added to previous responses to the question and the results are shown in a pop-up window. Visitors do not have to vote in order to see the results of the survey. They may also choose to *View Past Surveys (20.1)* & their results.

20.1 Survey Results

A pop-up window that reiterates the survey question and shows the current results of the survey.

20.2 Past Surveys

A list of past survey questions. Clicking on a question brings up a pop-up window with the results of that survey. The look of this pop-up window is identical to the window that shows the results of the current survey.

Appendix A: Menu Navigation *(see UniHomeConsumers.psd for examples)*

Clickable menu items (marked with an asterisk[*]) have a rollover state. Non-clickable menu items do not have a rollover state. Menu items that could lead to a page are followed by an asterisk enclosed in parentheses as shown here (*). *Menu items must be confirmed by Unilock.*

CONSUMERS

First Level	Second Level	Third Level
Design Ideas(*)	Design Fundamentals*	
	Driveways*	
	Entrances*	
	Patios*	
	Pools*	
	Steps*	
	Special Features*	
	Commercial (*) >	Golf Courses* Institutional* Municipal* Parks* Plazas* Special Features*
	Industrial (*) >	Driveways* Roadways* Parking Areas*
	Environmental (*) >	Parking Areas* Retention Ponds* Spillways*
	Installation of the Month*	
Products	Textured Pavers (*) >	Brussels Block* Il Campo* Optika* Series 3000* Stonehenge* Unigranite*
	Standard Pavers (*) >	Bullnose Paver* Camelot* Classico* Cortina* Hollandstone* Double Holland* Half Holland* Holland Edger* Olde Greenwich Cobble* Uni-Decor* Uni-Stone*

CONSUMERS (cont'd)

First Level	Second Level	Third Level
Products (cont'd)	Industrial Pavers (*) >	Anchorlock* Optiloc* Uni-stone*
	Environmental Pavers (*) >	Aquaterra* Dura-Mat* Ecoloc* Turfstone* Uni Eco-Stone*
	Garden Walls (*) >	Brussels Dimensional Stone* The Estate Wall* Quarrystone* Roman Stack* Stack Stone* Split 'N Stack*
	Retaining Walls (*) >	Concord Wall* Dura-Hold* Dura-Hold2* Pisa2* Pisa Reversible* Roman Pisa* Roman Wall* Siena Stone* Slope Block Mk IV*
	Accessories (*) >	Paver Sealant* Effluorescence Remover* Oil & Dirt Remover* Paint, Tar, and Rubber Remover* Polymeric Jointing Sand* Joint Stabilizer Sealer* Concrete Adhesive* Edge Restraint* Spikedge*
	Product Specifications*	
	Color Planner*	
Do-It-Yourself (*)	Design Fundamentals* Laying Patterns* Installation Instructions* Paver Quilting* Installation FAQs*	
Professional Installations*	Cost Estimator* Comparing Quotations* Request a Free Estimate*	
Events & Seminars (*)	DIY Seminars* Promotions* Other Events* <i>These menu items need to be confirmed.</i>	

CONTRACTORS

First Level	Second Level	Third Level
Design Ideas(*)	Residential (*) >	Driveways* Front Entrances* Patios* Pools* Steps* Special Features*
	Commercial (*) >	Golf Courses* Institutional* Municipal* Parks* Plazas* Special Features*
	Industrial (*) >	Driveways* Roadways* Parking Areas*
	Environmental (*) >	Parking Areas* Retention Ponds* Spillways*
Installation of the Month*		

Products (see *Consumers* page 40)

Resources & Training

Events & Seminars (*)	Contractor Seminars* Promotions* Other Events* <i>These menu items need to be confirmed.</i>
-----------------------	---

DESIGN PROFESSIONALS AND ENGINEERS

First Level	Second Level	Third Level
Design Ideas(*)	Commercial (*) >	Golf Courses* Institutional* Municipal* Parks* Plazas* Special Features*
	Industrial (*) >	Driveways* Roadways* Parking Areas*
	Environmental (*) >	Parking Areas* Retention Ponds* Spillways*
	Residential (*) >	Driveways* Front Entrances* Patios* Pools* Steps* Special Features*
	Installation of the Month*	
Products (see <i>Consumers</i> page 40)		
Resources		
Events & Seminars (*)	Lunch & Learn Info Sessions* Promotions* Other Events* <i>These menu items need to be confirmed.</i>	

DEALERS

First Level	Second Level	Third Level
Design Ideas(*)	Residential (*) >	Driveways* Front Entrances* Patios* Pools* Steps* Special Features*
	Commercial (*) >	Golf Courses* Institutional* Municipal* Parks* Plazas* Special Features*
	Industrial (*) >	Driveways* Roadways* Parking Areas*
	Environmental (*) >	Parking Areas* Retention Ponds* Spillways*
Installation of the Month*		
Products (see <i>Consumers</i> page 40)		
Dealer Support*		
Events & Seminars (*)	Dealer Events* Promotions* Other Events* <i>These menu items need to be confirmed.</i>	

Appendix B: Notes on Visual Design

This appendix contains some very abbreviated information on colors and fonts used on the website. Complete information must be extracted from the Photoshop templates supplied.

body	margin: 0px 0px 0px 0px
a: link	color: #336699 text-decoration: none
a: visited	color: #003366 text-decoration: none
a: hover	color: #ff9900 text-decoration: none
a: active	color: #ff3300 text-decoration: none
default body text	color: #333333 font-family: verdana, arial, sans-serif font-size: 11px line-height: 15 px
page title (image text)	font: DIN bold size: 26 pt (29.94 px) leading: 25.18 pt (29 px) tracking: -55 color: #CA361A
heading	color: #5E7069 font-family: arial, tahoma, sans-serif font-size: 14 px line-height: 15 px
sub-heading	color: #333333 font-family: verdana, arial, sans-serif font-weight: bold
notes (e.g. <i>UniEventListing</i>)	color: #999999 (usually) font-size: 10 px or 9 px line-height: 12 px

news item title (i.e., on user-type homepages)	color: #5E7069 font-family: verdana, arial, sans-serif font-weight: bold font-size: 11 px line-height: 14 px
news item blurb (i.e., on user-type homepages)	color: #999999 font-family: verdana, arial, sans-serif font-size: 10 px line-height: 14 px
warning or alert	color: #ff0000 font-family: verdana, arial, sans-serif font-weight: bold font-size: 10 px line-height: 12 px